

RACCORDS INSTANTANÉS



www.senga.fr

SÉRIE 5800X
ACIER INOXYDABLE

SENGA

CARACTÉRISTIQUES TECHNIQUES

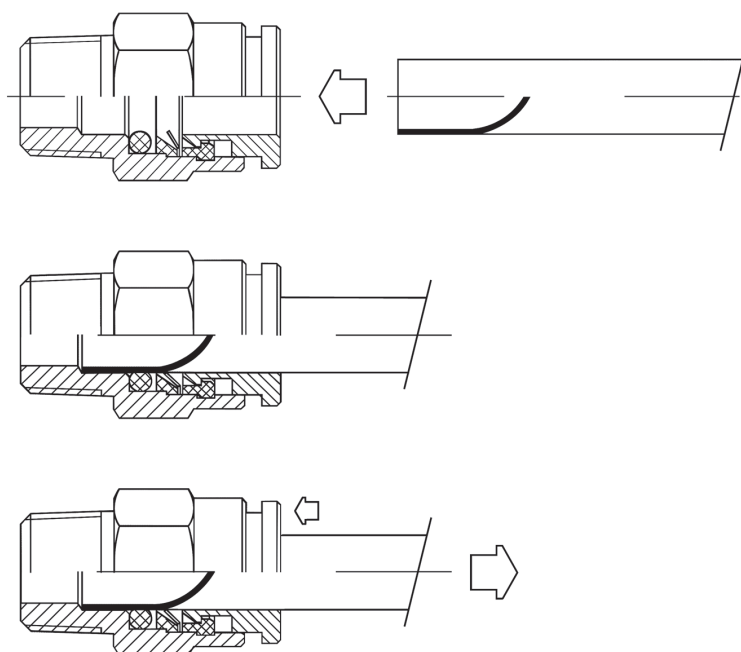
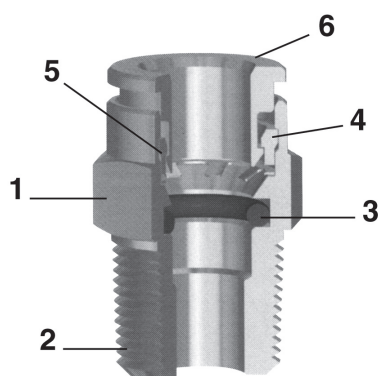

Matériaux et composants

- | | |
|--|---|
| 1. corps du raccord :
acier inoxydable AISI 316 L | 4. anneau de tenue :
acier inoxydable AISI 316 L |
| 2. embase filetée en acier inoxydable
AISI 316 L
filet conique BSP
filet cylindrique BSP avec joint monté FPM | 5. pince en acier inoxydable AISI 301 |
| 3. joint d'étanchéité en FPM | 6. poussoir en acier inoxydable
AISI 316 L |

anneau de maintien pour modèles orientables : acier inoxydable AISI 302

Champ d'application :

industrie chimique et alimentaire



tendue au vide :	-0,99 BAR
pression maximale d'exercice :	15 BAR
température de travail :	- 20°C / + 150°C

raccords d'implantation

5800 X



inox

droit mâle, BSP conique

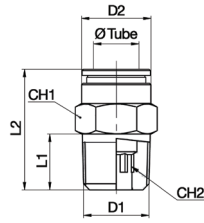

TYPE	tube	D1	D2	L1	L2	CH1	CH2
CODE							
5800X	4	1/8	9	7,5	15,5	10	3
5800X	4	1/4	9	11	20	14	3
5800X	6	1/8	12	7,5	20,5	12	4
5800X	6	1/4	12	11	20	14	4
5800X	8	1/8	14	7,5	24,5	14	6
5800X	8	1/4	14	11	23	14	6
5800X	8	3/8	14	11,5	22,5	17	6
5800X	10	1/4	16	11	30	16	8
5800X	10	3/8	16	11,5	23,5	17	8
5800X	10	1/2	16	14	27	22	8
5800X	12	1/4	19	11	32	19	8
5800X	12	3/8	19	11,5	27,5	19	10
5800X	12	1/2	19	14	27,5	22	10

5805 X

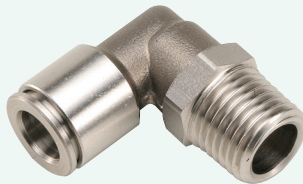

inox

équerre mâle, orientable, BSP conique

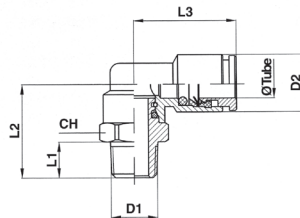

TYPE	tube	D1	D2	L1	L2	L3	CH
CODE							
5805X	4	1/8	9	7,5	17,5	17	10
5805X	6	1/8	12	7,5	20	21,5	13
5805X	6	1/4	12	11	24	21,5	14
5805X	8	1/8	14	7,5	20	22	13
5805X	8	1/4	14	11	24	22	14
5805X	8	3/8	14	11,5	25	22,5	17
5805X	10	1/4	16	11	26,5	25,5	16
5805X	10	3/8	16	11,5	27	25,5	17
5805X	10	1/2	16	14	32	26	22
5805X	12	1/4	19	11	30,5	28,5	21
5805X	12	3/8	19	11,5	30,5	28	21
5805X	12	1/2	19	14	33,5	28	22

5808 X



inox

T mâle, orientable, BSP conique

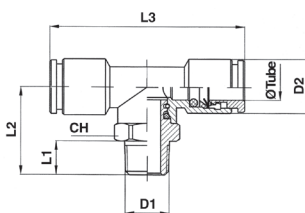

TYPE	tube	D1	D2	L1	L2	L3	CH
CODE							
5808X	4	1/8	9	7,5	21,5	34	10
5808X	6	1/8	12	7,5	20,5	42	13
5808X	6	1/4	12	11	24,5	42	14
5808X	8	1/8	14	7,5	20,5	43	13
5808X	8	1/4	14	11	24,5	43	14
5808X	10	1/4	16	11	27,5	51	16
5808X	10	3/8	16	11,5	28	51	17
5808X	12	3/8	19	11,5	31	57	21
5808X	12	1/2	19	14	34	57	22

5810 X



inox

équerre mâle, BSP conique

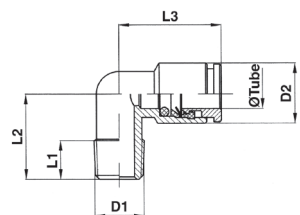

TYPE	tube	D1	D2	L1	L2	L3
CODE						
5810X	4	1/8	9	7,5	16	17
5810X	6	1/8	12	7,5	16	20
5810X	6	1/4	12	11	20	20
5810X	8	1/8	14	7,5	17	21
5810X	8	1/4	14	11	20	21
5810X	10	1/4	16	11	22,5	25,5

raccords d'implantation

5801 X

droit mâle, BSP cylindrique



inox

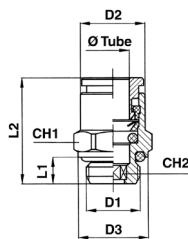

TYPE	tube	D1	D2	D3	L1	L2	CH1	CH2
CODE								
5801X	4	M5	9	8	4	19	9	-
5801X	4	1/8	9	13	5	16	13	3
5801X	6	M5	12	8	4	22,5	12	-
5801X	6	1/8	12	13	5	19	13	4
5801X	6	1/4	12	16	6,5	18,5	16	4
5801X	8	1/8	14	13	5	22,5	14	6
5801X	8	1/4	14	16	6,5	21	16	6
5801X	8	3/8	14	20	7	21,5	17	6
5801X	10	1/4	16	16	6,5	27,5	16	8
5801X	10	3/8	16	20	7	25	17	8
5801X	10	1/2	16	25	8,5	25,5	22	8
5801X	12	1/4	19	16	6,5	28,5	19	8
5801X	12	3/8	19	20	7	28,5	21	10
5801X	12	1/2	19	25	8,5	26,5	22	10

5806 X

équerre mâle, orientable, BSP cylindrique



inox

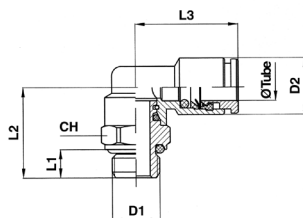

TYPE	tube	D1	D2	L1	L2	L3	CH
CODE							
5806X	4	M5	9	4	14	17	9
5806X	4	1/8	9	5	16	17	13
5806X	6	M5	12	4	15,5	20,5	9
5806X	6	1/8	12	5	18	21,5	13
5806X	6	1/4	12	6,5	20	21,5	16
5806X	8	1/8	14	5	18	22	13
5806X	8	1/4	14	6,5	20	22	16
5806X	8	3/8	14	7	22,5	22,5	21
5806X	10	1/4	16	6,5	22,5	25,5	16
5806X	10	3/8	16	7	24	25,5	21
5806X	10	1/2	16	8,5	29	26	22
5806X	12	1/4	19	6,5	26	28,5	21
5806X	12	3/8	19	7	26,5	28,5	21
5806X	12	1/2	19	8,5	31	28,5	22

5809 X

T mâle, orientable, BSP cylindrique



inox

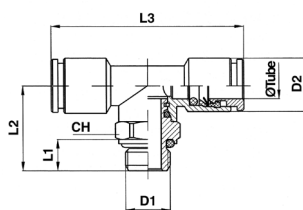

TYPE	tube	D1	D2	L1	L2	L3	CH
CODE							
5809X	4	M5	9	4	18	34	9
5809X	4	1/8	9	5	20	34	13
5809X	6	1/8	12	5	18,5	42	13
5809X	6	1/4	12	6,5	20,5	42	16
5809X	8	1/8	14	5	18,5	43	13
5809X	8	1/4	14	6,5	20,5	43	16
5809X	10	1/4	16	6,5	22,5	51	16
5809X	10	3/8	16	7	24,5	51	21
5809X	12	3/8	19	7	26,5	57	21
5809X	12	1/2	19	8,5	31	57	22

5859 X

broche encliquetable, piquage mâle, BSP cylindrique



inox

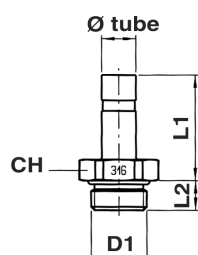

TYPE	tube	D1	L2	L1	CH
CODE					
5859X	4	1/8	5	21,5	13
5859X	6	1/8	5	22,5	13
5859X	6	1/4	7	23	17
5859X	8	1/8	5	24,5	13
5859X	8	1/4	7	25	17
5859X	10	1/4	7	29	17
5859X	10	3/8	8	29	19

raccords de jonction

5802 X



droit double égal et inégal

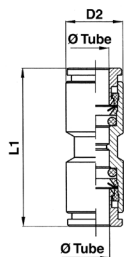

TYPE	tubes	D2	L1
CODE			
5802X	4	9	27
5802X	6	12	32,5
5802X	8	14	33
5802X	10	16	37,5
5802X	12	19	39,5
5802X	6-4	12	31
5802X	8-6	14	34
5802X	10-8	16	37
5802X	12-10	19	40

5807 X



équerre égale

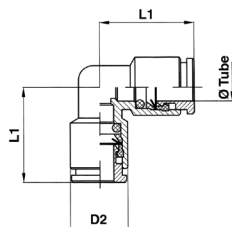

TYPE	tube	D2	L1
CODE			
5807X	4	9	17
5807X	6	12	20
5807X	8	14	21
5807X	10	16	25
5807X	12	19	27

5814 X



T égal

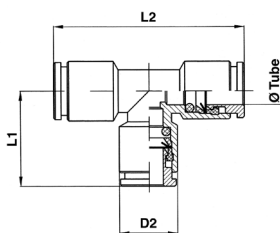

TYPE	tube	D2	L1	L2
CODE				
5814X	4	9	17	34
5814X	6	12	20	40
5814X	8	14	21	42
5814X	10	16	25	50
5814X	12	19	27	54

5825 X



réduction encliquetable

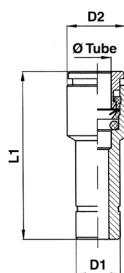

TYPE	tube	D1	D2	L1
CODE				
5825X	4	6	9	31
5825X	6	8	12	33
5825X	8	10	14	34,5

raccords de jonction

5816 X

traversée de cloison double

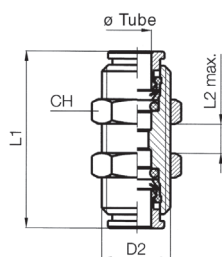

TYPE	tube	D2	L1	L2 max	CH
CODE					
5816X	4	M12x1	27	11	15
5816X	6	M14x1	32,5	16	17
5816X	8	M16x1	33	17	19
5816X	10	M18x1	37,5	19	21
5816X	12	M20x1	39,5	20	24

5895X

appareil à rainurer les tubes en acier inoxydable

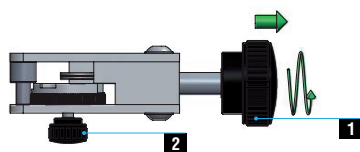

Phase 1. Faire reculer la lame de l'outil en dévissant complètement le bouton tournant (1).

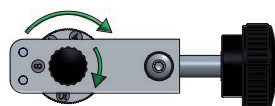

Phase 2. Dévisser le bouton tournant (2) et tourner le disque numéroté pour sélectionner la taille du tuyau à rainurer (maximum 12 mm). Une fois sélectionnée la taille du tuyau, visser jusqu'au serrage le bouton tournant (2) pour bloquer la taille.

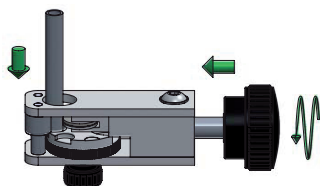

Phase 3. Insérer le tuyau dans le trou jusqu'au fond; visser le bouton tournant (1) afin que la lame soit contre le tuyau et continuer à serrer pour rainurer la surface du tuyau.

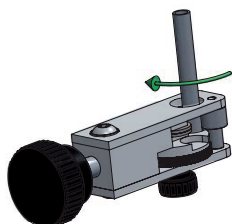

Phase 4. Tenir le tube et faire tourner l'outil tout autour du tuyau jusqu'à ce que l'on obtienne la rainure désirée.

CODE	diamètre tube maximum (mm)
5895X-INC	12